



Model No. DFC

Support 877-351-4702

DIGITAL ENHANCED GAS FIRED MODULATING CONTROL



This manual covers the following product(s):

DFC Direct Fired Control

Table of Contents

Overview.....	2
Normal Operation.....	2
Programming.....	3
Features.....	3
Valve Connections.....	4
Menu Map.....	5-6
Installation.....	6-7
Specifications.....	7
Temperature Resistance Chart.....	7

Overview

The Direct Fired Control (DFC) is a digital gas fired heating control. The control has a simple five button interface with a four digit LED display. All programmable parameters can be accessed through the system menu with the five button interface. The DFC's setpoint temperature sensing operation ranges from 40°F (4°C) to 250°F (121°C). There is a temperature sensor input that connects to provide a discharge temperature. The setpoint may be adjusted locally by the internal menu settings, by an external remote (DFTD or RDU), or with a 2-10VDC input. There is a combination of two modulating outputs that will power both 0-24V DC and 0-10V DC valve. System parameters are stored in non-volatile memory, and are retained even during a power outage. Also, the DFC is powered by 24V AC.

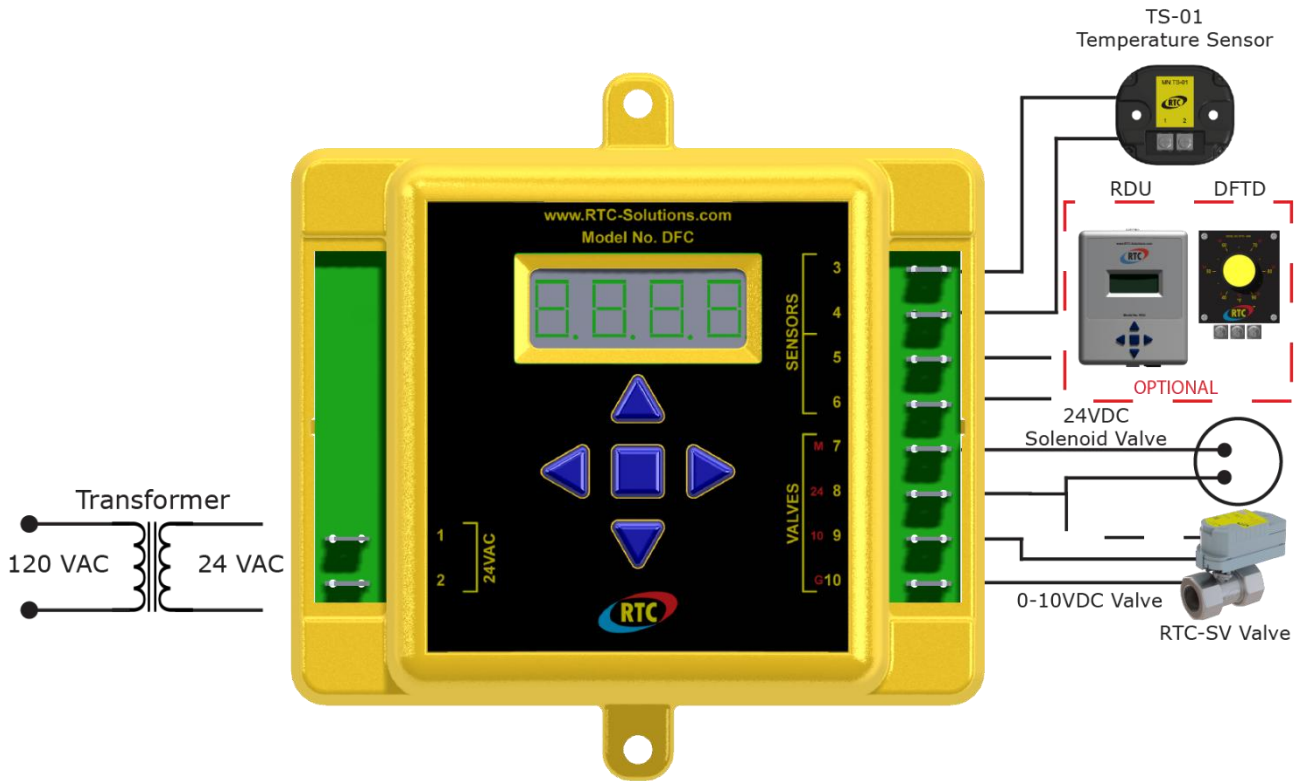

Figure 1: DFC Schematic Layout

Normal Operation

The DFC will always display the current discharge air temperature. Press the **UP** or **DN** key and the DFC will enter the "User Menu". Use the **UP** and **DN** keys to scroll through the different parameters and the **RT** key to enter the selected parameter. To change the discharge setpoint temperature press the **RT** key when on "SP". Once the key is pressed, the LED will display the text for the current setpoint temperature. Use the **UP** or **DN** key in order to set a new discharge temperature. Then press the **ENT** key to save the changes made. If a key is not pressed for 10 seconds, the DFC will exit without saving. When adjusting the setpoint range, the setpoint cannot surpass the set Low and High values. For instance, if Low ("SPLo") is set to 80°F and High ("SPHi") is set to 150°F, the setpoint is adjustable between 80°F to 150°F.

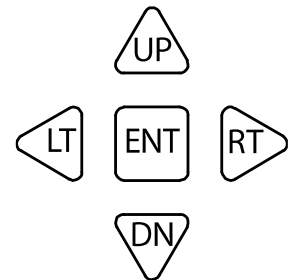

Figure 2: DFC Keys

Programming

Please refer to the "System" and "User" Menu Maps on pages 5 and 6 for programming. To enter the "User Menu", press the **UP▲** or **DN▼** key. To enter the "System Menu, hold the **ENT** key down for 3 seconds until "SPLo" is displayed. In both menus use the **UP▲** and **DN▼** keys to navigate to the desired menu parameter as shown in column 1 of the Menu Maps. To edit a menu parameter, press the **RT▶** key once on the desired parameter.

Displayed will be the current value of that parameter as shown in column 2. Use the **UP▲** and **DN▼** keys again to edit the parameters for column 2. Press the **ENT** key to save the changes made or the **LT◀** key to cancel without saving and return to column 1. If a key is not pressed for 10 seconds or the **ENT** key is held for 3 seconds while in program mode, the control will return to normal mode.

Features

Alarms:

Error messages on the DFC will be scrolled across the display with a detailed message. This will allow users to realize the issue in order to resolve the error faster. Below are the list of errors and their meanings.

1. "TS oPEn" - There is no Discharge Temperature Sensor connected to the DFC. Therefore, no discharge temperature reading can be made.
2. "RDU oPEn" - The user has the Remote ("rEtd") parameter on the DFC enabled, but no external control is found to take a reading.
3. "TS ShortEd" - There is a short in the connection of the Discharge Temperature Sensor.
4. "RDU ShortEd" - The user has the Remote ("rEtd") parameter on the DFC enabled and there is a short in the connection.
5. "Hi V" - Voltage has exceeded 10.5VDC (while using 2-10VDC input)
6. "no V" - Voltage is lower than 1.5VDC (while using 2-10VDC input)
7. "SC" - When thermostat connection is shorted the control will revert to the "dhi" parameter.
8. "SO" - When thermostat connection is open the control will revert to the "SP" parameter.
9. "NO S" - Error when thermostat connection is not open or closed.
10. "init" - Initializing control startup.

To resolve an issue check the wiring connections. Please refer to "Installation" on page 5 for proper terminal connections.

Password:

When trying to access program mode, if the DFC is password protected the display will show "PASS". Otherwise the display will show "SPLo", which is the start of program mode. If password protected no menu settings may be altered until the correct password is entered. In order to enter the password press the **ENT** key while "PASS" is displayed and use the **UP▲** and **DN▼** keys to set the DFC to the factory set password (21). Once on the number 21, press the **ENT** key again to access program mode. If the wrong password is entered then the DFC will return to normal mode.

User Menu:

1. Setpoint("SP") allows the user to adjust the temperature setpoint.
2. Remote Setpoint("rESP") allows the user to view the current remote setpoint.
3. Remote Temperature Dial("rEtd") allows the user to use temperature control locally or with a remote(thermostat, RDU, or 2-10VDC input).
4. Discharge High("dhi") allows the user to set the discharge high temperature. Discharge High("dhi"), when the remote is set to thermostat("StAt"), will be engaged when the thermostat calls for heat.
5. Fahrenheit or Celsius("ForC") allows the user to view whether the DFC is set to read temperature in Fahrenheit or Celsius.
6. Voltage("voLt") allows the user to view the current voltage when the remote is set to "volt" (2-10VDC input).

Modulating Valve Outputs:

The DFC has the ability to power either a 24V DC or a 10V DC modulating valve. Only one valve at a time may be connected.

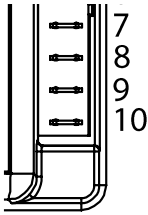

7	PWM For Solenoid Valve
8	24VDC Valve Output
9	0-10VDC Valve Output
10	Valve Ground

Connection for 0-24V DC use terminals 7 and 8

Connection for 0-10V DC use terminals 8, 9, and 10

Figure 3: DFC Modulating Output Terminals

Valve Connections

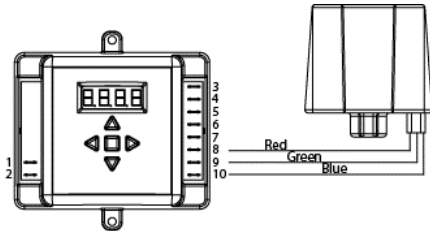

For Enolgas Actuator
 Red to Terminal 8 (24VDC)
 Blue to Terminal 10 (Ground)
 Green to Terminal 9 (0-10VDC Input)
 Pink to No Connect (0-10VDC Output)

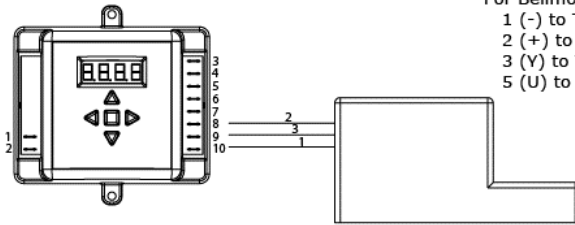

For Belimo Actuator
 1 (-) to Terminal 10 (Ground)
 2 (+) to Terminal 8 (24VDC)
 3 (Y) to Terminal 9 (2-10VDC Input)
 5 (U) to No Connect (2-10VDC Output)

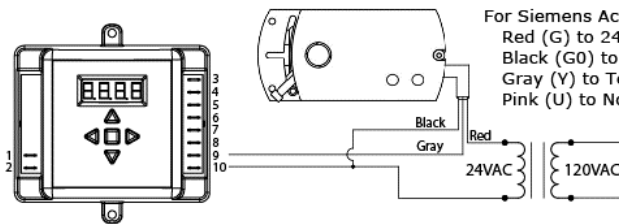

For Siemens Actuator
 Red (G) to 24VAC Transformer (24VAC)
 Black (G0) to 24VAC Transformer & Terminal 10 (Ground)
 Gray (Y) to Terminal 9 (0-10VDC Input)
 Pink (U) to No Connect (0-10VDC Output)

DFC	Solenoid	ACT-4.0	Belimo	Siemens
Term 7: PWM	PWM			
Term 8: 24VDC	24VDC	Red: 24VDC	2: 24VDC	Red: 24VAC
Term 9: 0-10V Output		Green: 0-10V Input	3: 2-10V Input	Gray: 0-10V Input
Term 10: Ground		Blue: Ground	1: Ground	Black: Ground

System Menu Map

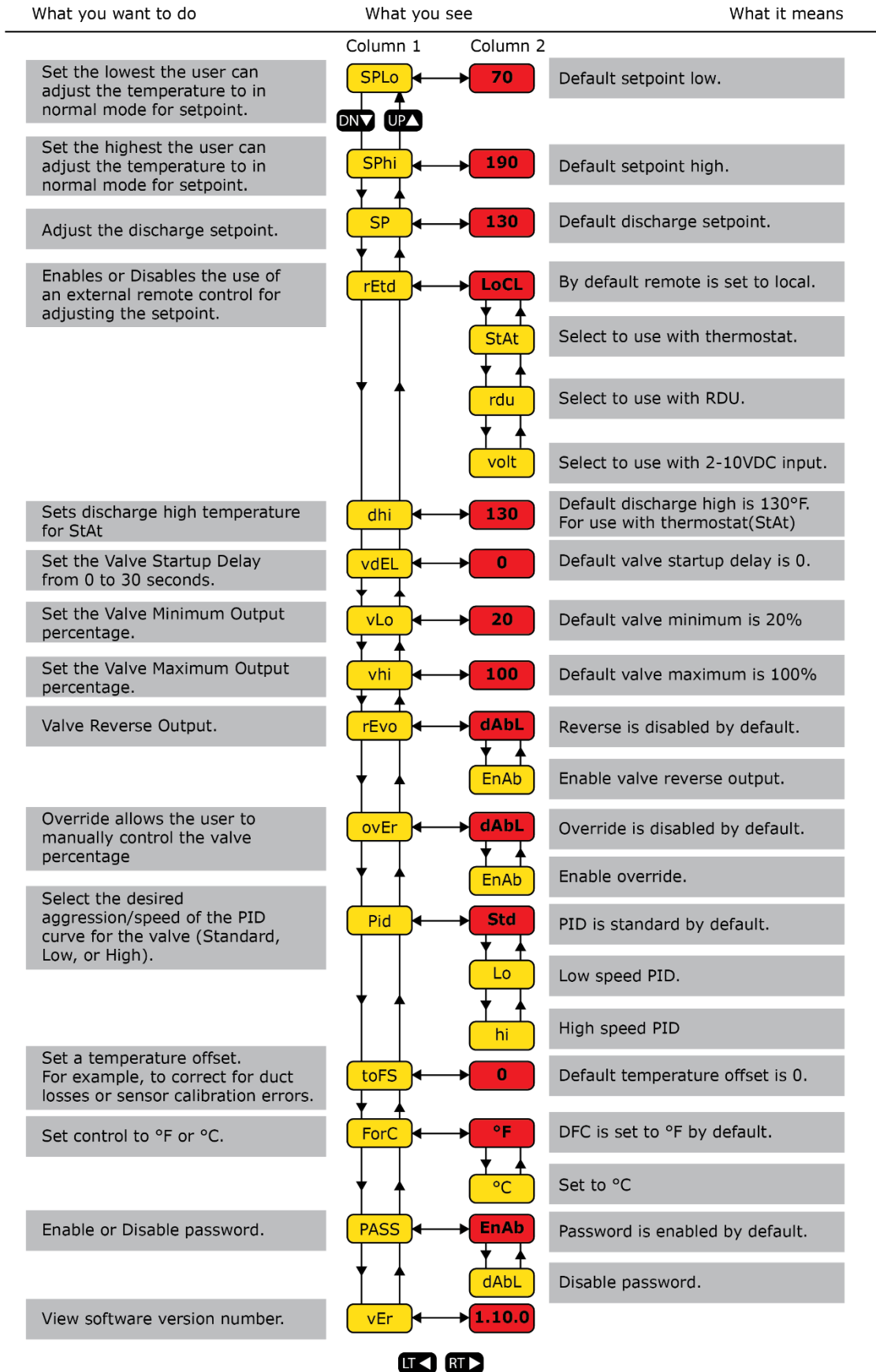

User Menu Map

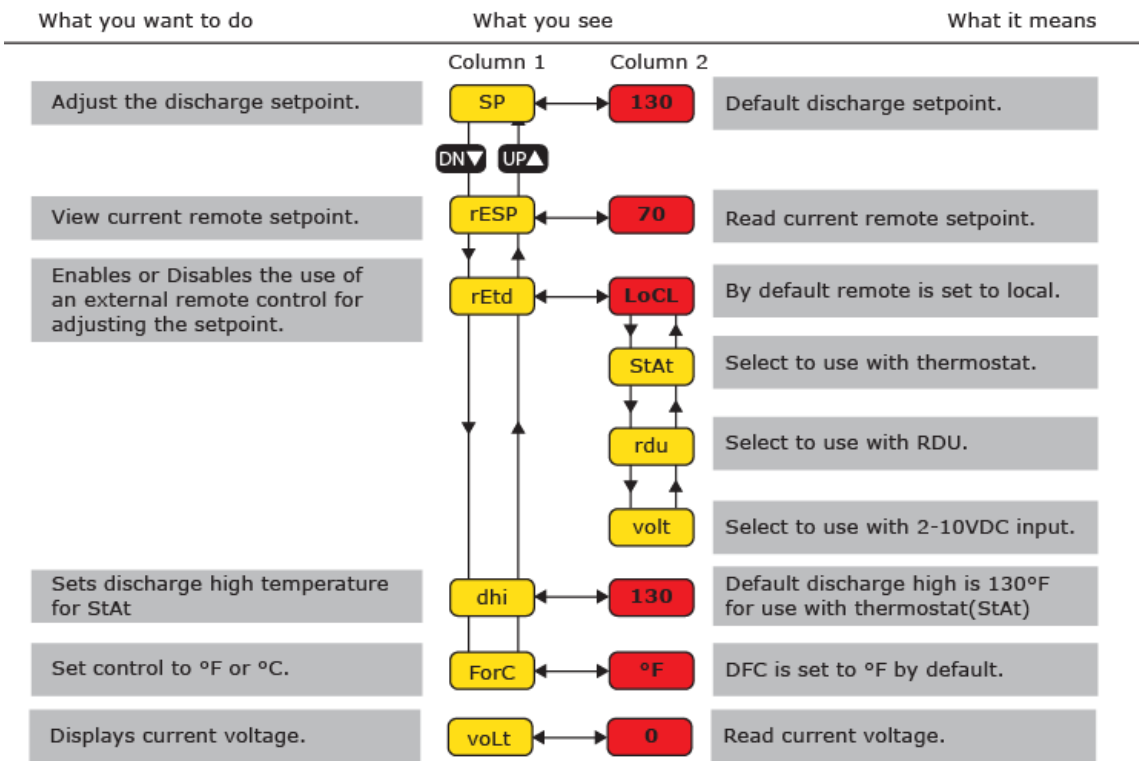

Installation

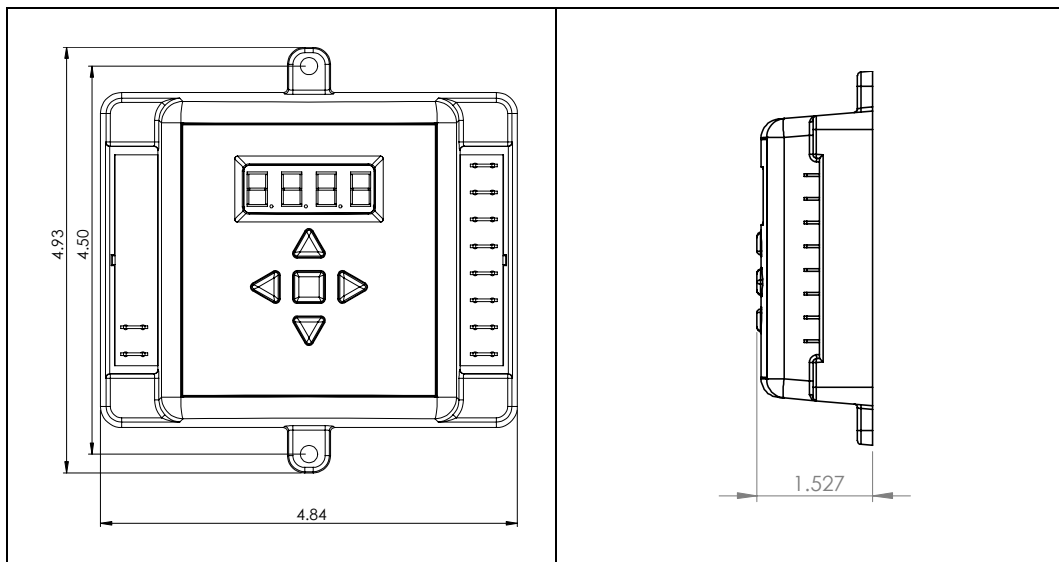

Figure 4: DFC Front Panel

Figure 5: DFC Side view

All dimensions are in inches

Wiring for the DFC is convenient for the user with easy access to all terminal connections.



Figure 6: DFC Terminal Number Layout

1	24VAC
2	24VAC
3	TS-01
4	TS-01
5	DFTD or RDU
6	DFTD or RDU
7	PWM for Solenoid Valve
8	24VDC Valve Output
9	0-10VDC Valve Output
10	Valve Ground
V+	Positive 2-10VDC Input
V-	Negative 2-10VDC Input

Specifications

Power Requirements

24V AC Nominal
(18VAC/DC - 26VAC/DC)

Current Rating 24V Output

1A

DFC Ambient Temperature Limits
Operating

-40-149°F (-40-65°C)

Accuracy

+/-3°F (1°C)

Temperature Resistance Chart

Temp °F	Temp °C	Sensor Resistance		Dial Resistance				
		40-90	80-130	120-170	160-210	200-250		
40	4.4	11214	11250					
50	10.0	11029	11050					
60	15.6	10835	10850					
70	21.1	10635	10650					
80	26.7	10429	10450	10380				
90	32.2	10219	10250	10180				
100	37.8	10005		9980				
110	43.3	9789		9780				
120	48.9	9573		9580	9590			
130	54.4	9356		9380	9390			
140	60.0	9142			9190			
150	65.6	8930			8990			
160	71.1	8723			8790	8700		
170	76.7	8521			8590	8500		
180	82.2	8325				8300		
190	87.8	8138				8100		
200	93.3	7959				7900	8060	
210	98.9	7791				7700	7860	
220	104.4	7634					7660	
230	110.0	7490					7460	
240	115.6	7360					7260	
250	121.1	7246					7060	